

# **GUEST**

**MODEL 729829-P  
CONTROL PANEL FOR  
298-5, 503 AND 503A SPOTLIGHTS**

**INSTALLATION AND OPERATION  
INSTRUCTIONS**

**IMPORTANT !  
READ THESE INSTRUCTIONS BEFORE  
INSTALLING THIS PRODUCT.**

**KEEP THESE INSTRUCTIONS FOR FUTURE REFERENCE.**

## Mounting the Control Panel

1. Select a convenient mounting location for the control panel. Be sure you will have access to the area behind the location, and that you will be able to drill holes there without damaging existing wiring or structures. Do not place the control where it could interfere with the safe operation of the vessel or vehicle. Avoid mounting the control panel on a curved surface, or flat on its back in a location that would be exposed to direct rain or spray.
2. Use the small foam gasket included in the box as a template to mark the location of the holes to be drilled. Drill two 3/16" (5mm) holes for the mounting screws and one 1/2" (13mm) hole in center through the mounting surface as shown in sketch below (not to scale), make sure that the holes are horizontal to each other.

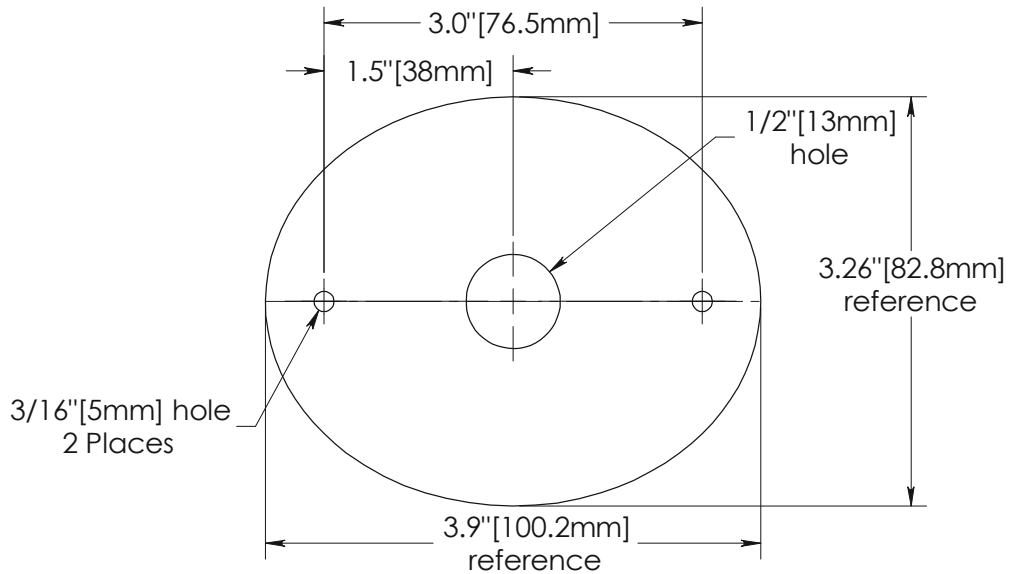

3. Feed all of the Control Panel wires through the center hole of the small gasket, then place the gasket underneath the control through the two threaded mounts.

Feed all the control wires through the 1/2" (13mm) drilled hole of mounting surface, a *small* amount of a non-silicone sealant, (such as StarBrite® Boat Caulk #83801) can be applied where the wires penetrate the mounting surface.

Fasten the control onto mounting surface using the provided two flat fender washers and lock nuts. Tighten the nuts enough to slightly compress the small gasket.

## Electrical Connections

The Guest Model 298-5, 503, & 503A spot/flood light has two types of wiring connections.

They are:

- *Power supply wires* - the red (+) and black (-) wires that bring 12 volts DC power to the spot/flood light and to the control panel.
- *Control cable wires* - the small wires within a gray casing that carry your commands from the control panel to the spot/flood light.

### **CAUTION!**

**DO NOT CONNECT THE CONTROL WIRES (with connectors) TO ANY POWER SUPPLY WIRES.  
DO NOT REVERSE THE RED (POSITIVE) AND BLACK (NEGATIVE) POWER WIRES.**

This spot/flood light requires a source of 12 volt DC power that is capable of supplying 10 amps of current even when other equipment is operating. For best results, run two new wires from the red (+) positive and black (-) negative power wires of the light directly to the main 12 volt DC accessory panel. Install fuse and fuse holders as shown in diagram. A 10 amp circuit breaker can be installed instead of an in-line 10 amp fuse. If the light will be less than 30 feet (9m) from its power source, use 12 gauge (3mm) power supply wires. If the distance will be more than 30 feet (9m), use 10 gauge (5mm) wires.

An in-line fuse and holder should be installed on the red 22 awg power wire for the control.

**Complete the wiring connections as shown below:**

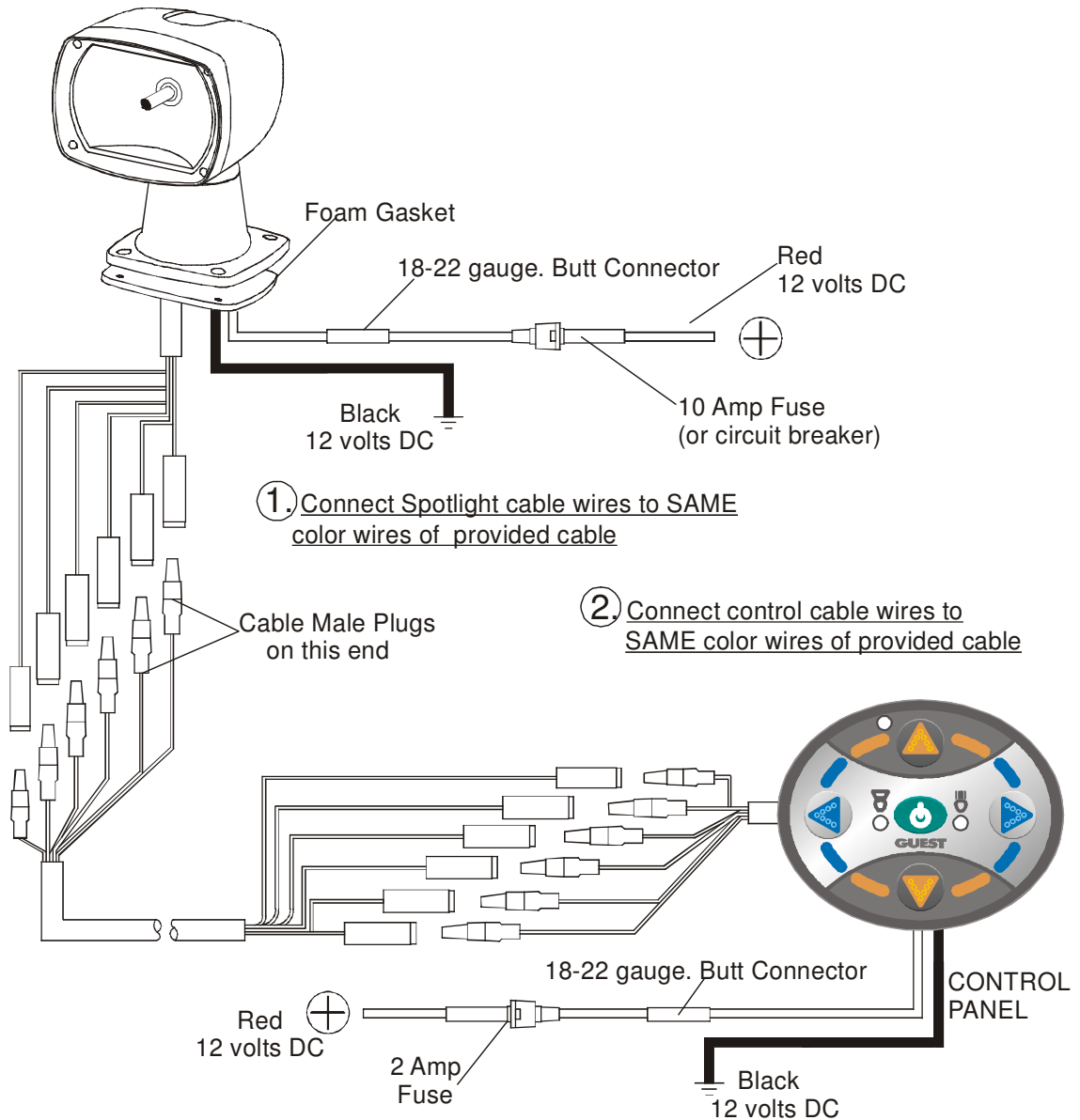

**Note:** When connecting to a 298-5 spotlight you will need to cut off the terminals, strip insulation back, and splice into existing control cable by matching the same color.

## Operation

To move the spotlight, press one of the directional switches firmly. By pressing a horizontal switch and a vertical switch together, the light will move both vertically and horizontally at the same time.

Pressing the Green center switch once will activate the 100 watt spotlight beam. Pressing the same switch 2 or 4 times will turn off all lights. Pressing the same switch 3 times will activate the 55 watt floodlight beam. This applies on initial start up or if power has been disconnected.

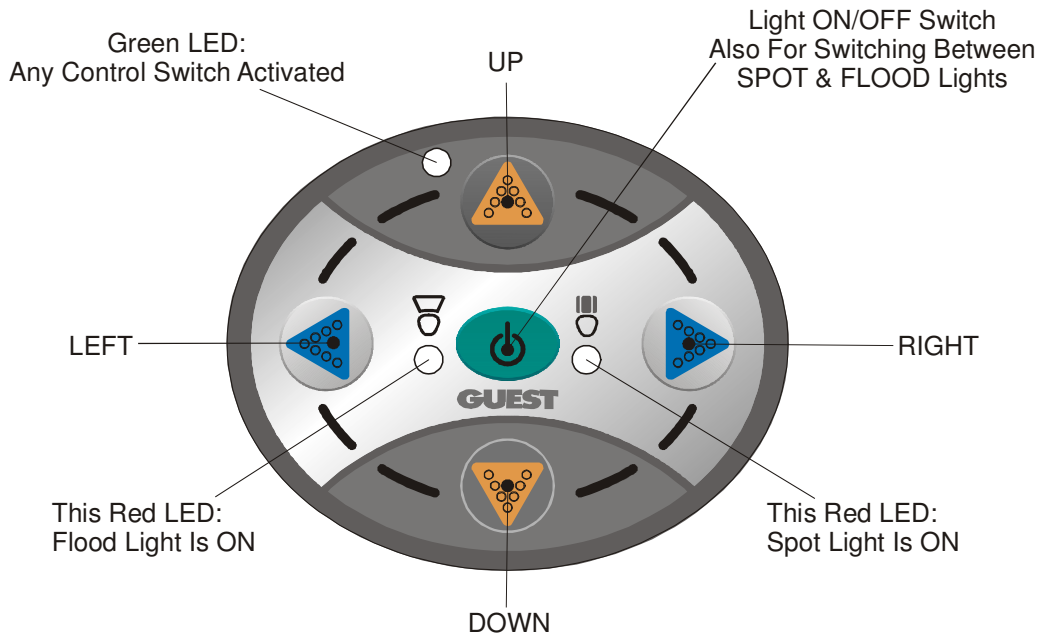

## Precautions

**DO NOT** look directly into the spotlight or floodlight while it is operating.

**DO NOT** cover the light with a fabric cover or any other flammable material. Accidental activation may result in a fire hazard.

**DO** turn the spotlight toward the control station when not in use. If the spotlight is accidentally activated during daylight, the operator will be more likely to notice and turn the spotlight off before draining a battery.

## LIMITED WARRANTY

For one (1) year from the date of original purchase, The Guest Co. will, at its discretion, repair or replace for the original consumer, free of charge, any parts found defective in material or workmanship. All transportation charges under this warranty must be borne by the consumer.

Proof of purchase is required: A computerized register receipt is required. Hand-written receipts are not accepted for warranty proof of purchase. In the absence of a receipt, warranty period will be calculated from date of manufacture printed or stamped on the product.

There is no other expressed warranty. Implied warranties, including those of merchantability and fitness for a particular purpose, are limited to one year from the date of purchase. This is the exclusive remedy and consequential damages are excluded where permitted by law.

Tel: (707)226-9600  
Fax: (707) 226-9670

Email: [info@marinco.com](mailto:info@marinco.com)  
Website: [www.marinco.com](http://www.marinco.com)

730332 REV B 3429