

GUEST

MODEL 500A BEAMER

REMOTE CONTROL SPOTLIGHT

INSTALLATION AND OPERATION
INSTRUCTIONS

IMPORTANT !
READ THESE INSTRUCTIONS BEFORE
INSTALLING AND USING THIS PRODUCT.

KEEP THESE INSTRUCTIONS FOR FUTURE REFERENCE.

Description

The GUEST 500A remote control spotlight uses a sophisticated, high-powered halogen bulb. The penetrating 100-watt beam can illuminate objects up to one (1) mile away.

All Guest Beamer spotlights can rotate 355° and move up and down through an 80° arc. Although the model 500A cannot be upgraded for wireless control, multiple control panels can be installed using the 729824-P dual station control. The model 500A comes complete with spotlight, and remote control panel.

This unit is designed for 12 volt operation only.

<i>p</i>	<i>#</i>	<i>Tools and additional materials required</i>
		Electric drill with 1/2"(13mm), 5/16"(8mm) and 3/16"(5mm) bits
		Wire crimping tool
		Phillips-head screwdriver
	2	7/16", (11mm) wrenches
		Non-silicon sealant (StarBrite® Boat Caulk #83801 or equivalent.)
	4	1/4" (6mm) Stainless Steel pan or socket head machine bolts (Bolt length = mounting surface thickness plus 1" (25mm))
	4	1/4" (6mm) Stainless Steel large O.D. flat fender washers, lock washers and hex nuts.
	1	10 amp fuse and fuse holder (or circuit breaker)
	1	2 amp fuse and fuse holder (or circuit breaker)
		Marine grade plywood

		You will also need marine grade stranded, 2-conductor, 12-gauge wire to connect the spotlight and the control panel to 12-volt DC power sources. (Use 10-gauge wire if the light will be more than 30 feet (9mm) from its power source.)
--	--	--

Installation

Mounting the Spotlight

1. Select a horizontal , smooth surface to mount the spotlight on. Be sure you will have access to the underside of the chosen location, and that you will be able to drill holes there without damaging existing wiring or structures. Avoid locations where lines, anchors, sails or other hazards might cause damage to the light.

***NOTE:** Mounting the light as far forward or as high as possible can help to reduce reflected glare from the deck when the light is in use.*

2. Remove the large foam gasket from the box and use it as a template for the footprint of the light. **Note:** Front mounting holes are further apart than rear mounting holes. Mark the location of the four corner holes and the center hole squarely onto the mounting surface with pencil.
3. Drill four 5/16" (8mm) holes and one 1/2" in the center through the mounting surface at the marked points.

***NOTE:** Always wear eye protection when using power tools.*

4. Install the foam gasket on to the base of the spotlight, making sure that all eight wires exit through the center hole in the gasket.
5. Feed the Three wires coming out of the base of the light through the center hole in the mounting surface. A *small* amount of a *non*-silicone sealant, (such as StarBrite® Boat Caulk #83801), can be applied to where the bolts and the wires penetrate the mounting surface.

CAUTION!

Silicone based sealants may cause damage to the foam gasket or to the base of the light.

6. It is recommended that you use marine grade plywood as a back-plate.

7. Place the light on the mounting surface, lens facing forward, and align the 4 holes in the light base and the foam gasket with the 4 corner holes drilled into the mounting surface.
8. Fasten the spotlight securely to the mounting surface using four 1/4" (6mm) bolts, flat washers, lock washers and nuts (not included). Do not over tighten. Large flat fender washers are recommended.
9. Install the white control cable between the light and the planned location of the control panel. Avoid running the cable across sharp edges or where it may be exposed to extreme heat.

Mounting the Control Panel

1. Select a convenient mounting location for the control panel. Be sure you will have access to the area behind the location, and that you will be able to drill holes there without damaging existing wiring or structures. Do not place the control where it could interfere with the safe operation of the vessel or vehicle. Avoid mounting the control panel on a curved surface, or flat on its back in a location that would be exposed to direct rain or spray.
2. Use the small foam gasket included in the box as a template to mark the location of the holes to be drilled. Drill two 3/16" (5mm) holes for the mounting screws and one 1/2" (13mm) hole in center through the mounting surface as shown in sketch below (not to scale), make sure that the holes are horizontal to each other.

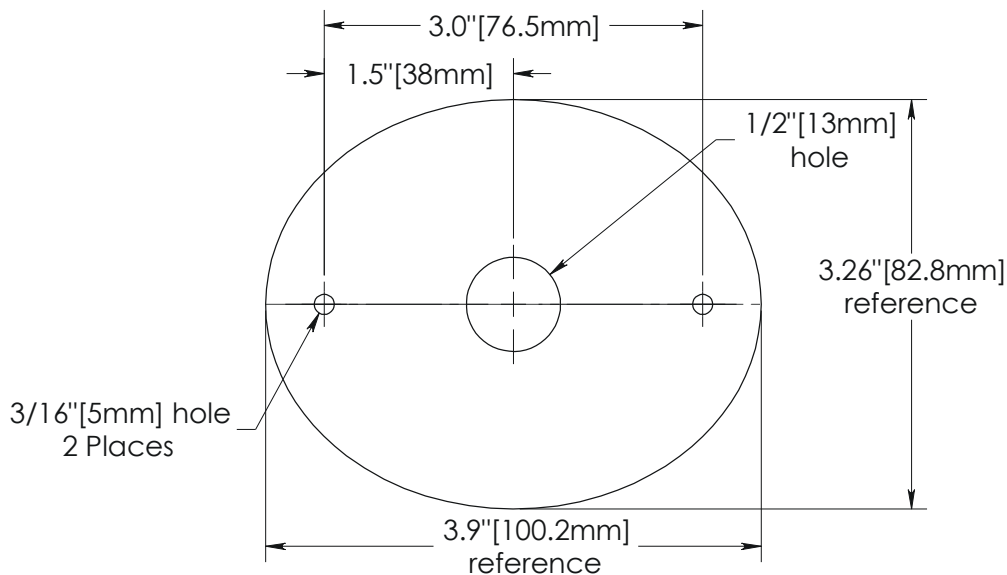

3. Feed all of the Control Panel wires through the center hole of the small gasket, then place the gasket underneath the control through the two threaded mounts.

Feed all the control wires through the ½" (13mm) drilled hole of mounting surface, a *small* amount of a non-silicone sealant, (such as StarBrite® Boat Caulk #83801) can be applied where the wires penetrate the mounting surface.

Fasten the control onto mounting surface using the provided two flat fender washers and lock nuts. Tighten the nuts enough to slightly compress the small gasket.

Electrical Connections

The Guest Model 500A Spotlight has two types of wiring connections.

They are:

- *Power supply wires* - the larger red (+) and black (–) wires that bring 12 volts DC power to the spotlight and to the control panel.
- *Control cable wire* - The White wire carries your commands from the control panel to the spotlight.

CAUTION!

**DO NOT CONNECT THE WHITE CONTROL WIRES
TO ANY POWER SUPPLY WIRES.**

**DO NOT REVERSE THE RED (POSITIVE)
AND BLACK (NEGATIVE) POWER WIRES.**

Connect the white control wire between the control panel and the spotlight. Use 22-gage (AWG) stranded wire, larger diameter wire (under 22 AWG) is not recommended.

IMPORTANT

The White control wire will carry digital signals. It is necessary to make all the white wire connections as tight and corrosion resistant as possible for proper operation. For best

results use waterproof telephone splices or solder the wire connections, and then cover them with heat-shrink tubing.

This spot/flood light requires a source of 12 volt DC power that is capable of supplying 10 amps of current even when other equipment is operating. For best results, run two new wires from the red (+) positive and black (-) negative power wires of the light directly to the main 12 volt DC accessory panel. Install fuse and fuse holders as shown in diagram. A 10 amp circuit breaker can be installed instead of an in-line 10 amp fuse. If the light will be less than 30 feet (9m) from its power source, use 12 gauge (3mm) power supply wires. If the distance will be more than 30 feet (9m), use 10 gauge (5mm) wires.

Complete the wiring connections as shown below:

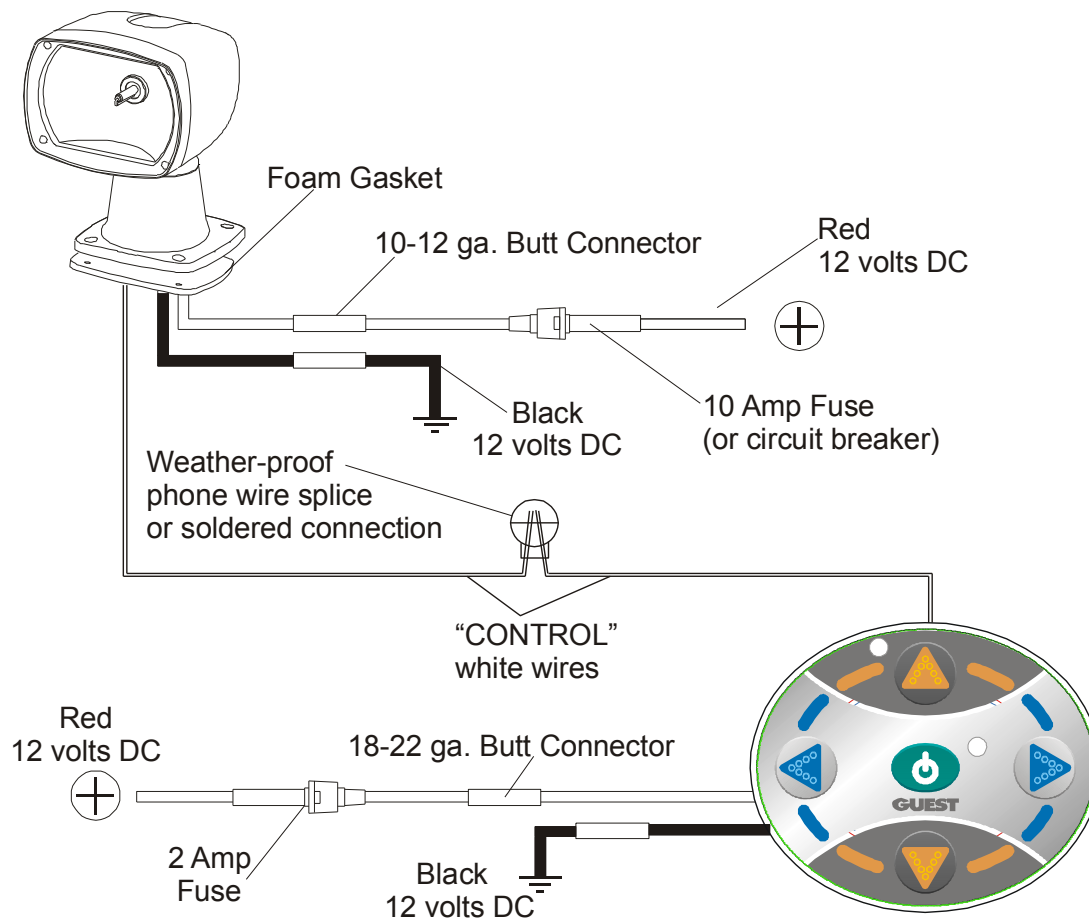

Operation

To move the spotlight, press one of the directional buttons firmly. By pressing a horizontal button and a vertical button together, the light will move both vertically and horizontally at the same time..

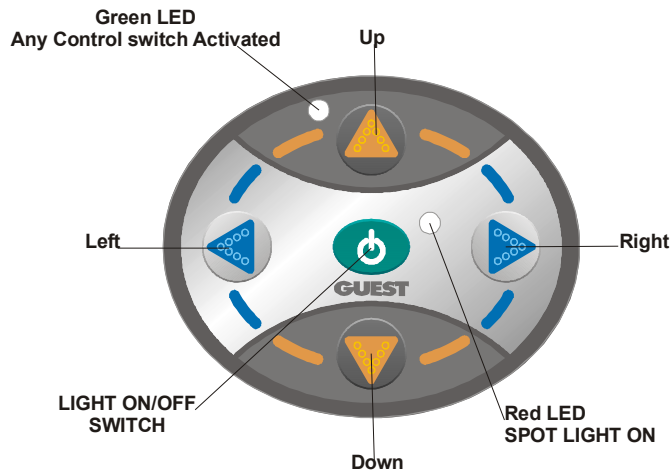

Precautions:

DO NOT look directly into the spotlight while it is operating.

DO NOT cover the light with a fabric cover or any other flammable material. Accidental activation may result in a fire hazard.

DO turn the spotlight toward the control station when not in use. If the spotlight is accidentally activated during daylight, the operator will be more likely to notice and turn the spotlight off before draining a battery.

Maintenance:

Under normal conditions, mild detergent and water will be sufficient to keep the spotlight clean. Avoid using caustic chemicals or abrasives as they may damage the housing. No lubrication is necessary.

For replacement parts you can call the Guest Co. at 203-235-4421 or contact your local dealer.

<i>Item</i>	<i>Part #</i>
Replacement 100 Watt bulb kit	729493
Control panel, 500A	729823-P
Dual Station Kit, 500A	729824-P
Lower drive motor (left/right)	U-3135

Base mounting gasket For Spotlight	728372
Safety glass lens	B-23186
Relay PC Board 500A	730511
Spotlight Reflector	D-23127
Gasket For Control Panel	729962

NOTE:

*THE CONTROL PANELS USED WITH GUEST MODELS 501A, 502A, OR 503A WILL **NOT** OPERATE THE MODEL 500A SPOTLIGHT.*

Troubleshooting

Under normal use, your Guest Beamer spotlight will provide you with many years of reliable service.

If an operational problem occurs:

Confirm that all fuses are intact. If a fuse *has* blown, do not replace the fuse until the cause of the problem has been located and corrected. NEVER replace a blown fuse with a higher value fuse.

Most problems are caused by poor wiring connections. Confirm that all wiring connections are accurate and well made. Be sure that the spotlight and control are connected to a 12 volt DC power source capable of supplying 10 amps even while other equipment is operating. (See diagram on page 5.)

If the spotlight does not move or light, remove the 4 bolts that fasten the spotlight onto the mounting surface and gently lift the light until you can see inside its base . Avoid cutting any wires. Gently inspect the base for broken connections. Examine the circuit board for loose plug connectors, blackened components or corrosion. Replace the circuit board if it appears damaged. If there are no loose wires or signs of water penetration, re-install the spotlight and then replace the control pad.

If the spotlight moves properly but does not light, examine the halogen bulb. Replace it if it appears discolored or broken. If the bulb appears normal, test for a faulty relay by listening at the base of the light while someone else activates the bulb using the control panel. If no "click" is audible, or if a "chattering" sound is not heard, replace the Relay. NOTE: Low voltage or a faulty circuit board may cause similar symptoms.

If the spotlight will not move left or right but operates normally otherwise, listen at the base of the light while someone else presses the left or right directional buttons. If the lower motor makes no sound when it is activated, replace the lower motor.

If the spotlight does *not* move in one direction only (up, but not down or left, but not right), and the wiring has been checked, replace the control panel.

If your light has a problem that is not described above, contact the Guest Company Service Department for assistance at (203) 235-4421.

LIMITED WARRANTY

For one (1) year from the date of original purchase, The Guest Co. will, at its discretion, repair or replace for the original consumer, free of charge, any parts found defective in material or workmanship. All transportation charges under this warranty must be borne by the consumer.

Proof of purchase is required: A computerized register receipt is required. Handwritten receipts are not accepted for warranty proof of purchase. In the absence of a receipt, warranty period will be calculated from date of manufacture printed or stamped on the product.

There is no other expressed warranty. Implied warranties, including those of merchantability and fitness for a particular purpose, are limited to one year from

the date of purchase. This is the exclusive remedy and consequential damages are excluded where permitted by law.

The Guest Co.
95 Research Parkway
Meriden, CT 06450, USA

Tel: (203) 235-4421
info@guestco.com

Email:

Fax: (203) 235-0039

Website: www.guestco.com

730385 REV A