



Cruising Charger Series **OWNER'S MANUAL**

ON BOARD BATTERY CHARGERS

<u>Models</u>	<u>DC Amperage</u>	<u>No. Of Banks</u>	<u>Volts</u>
2632A 2632A-230	5,5,20 Amps	3 Bank	12/12/12
2633A 2633A-230	10,20 Amps	2 Banks	12/12

*** : See Section 3 diagrams for specific connection instructions**

IMPORTANT NOTICE

This manual contains important safety and operating instructions for the charger. Read the entire manual before using. Also read all instructions and cautions for and on the charger, batteries and equipment in the vicinity of the batteries.

1. INTRODUCING THE CHARGER

The Guest model 2632A, and 2633A are designed to recharge your batteries, and extend your battery's life in applications where it is stored for long periods of time. They are "3-stage" electronic, lightweight, silent, completely automatic battery chargers. Each output produces 12 Volts DC at a full 5 Amps, 10, or 20 Amps (model specific), while using much less AC current than other charger types. Unlike automotive "trickle" chargers, the 2632A, and 2633A will not boil off the electrolytes in properly installed and maintained batteries. The red and green LED's, mounted on the charger face let you know the unit is *recharging* and *maintaining* your batteries. This sophisticated device is ideal for recharging and maintaining the 12VDC batteries in your boat, electric vehicle or cart, ATV, snowmobile or motorcycle.

SAVE THESE INSTRUCTIONS

WARNINGS

THIS CHARGER SHOULD BE USED TO CHARGE ONLY LEAD ACID, AGM, OR GEL CELL TYPE BATTERIES. USE ON OTHER BATTERY TYPES MAY CAUSE AN EXPLOSION OR PERSONAL INJURY.

RISK OF EXPLOSIVE GASES! WORKING IN THE VICINITY OF LEAD ACID BATTERIES IS DANGEROUS. BATTERIES GENERATE EXPLOSIVE GASES DURING NORMAL OPERATION. THEREFORE IT IS OF THE UTMOST IMPORTANCE THAT EACH TIME BEFORE USING YOUR CHARGER YOU FOLLOW THE INSTRUCTIONS EXACTLY.

Personal Safety Precautions

Adhere to the following personal safety precautions when installing or working with the chargers:

1. Someone should be within voice range or close enough to come to your aid when you work near a lead-acid battery.
2. Have plenty of fresh water and soap nearby in case battery acid contacts skin, clothing, or eyes.

Personal Safety Precautions (cont'd)

3. Wear complete eye protection and clothing protection. Avoid touching eyes while working near a battery.
4. If battery acid contacts skin or clothing, wash them immediately with soap and water. If acid enters the eye, flood the eye with cold, running water for at least ten minutes and get medical attention.
5. Never smoke or allow an open flame in the vicinity of the battery.
6. Do not drop a metal tool onto the battery. It may spark, short circuit the battery, or may cause an explosion.
7. Remove all personal metal items such as rings, bracelets, necklaces, and watches when working near a lead-acid battery. A battery can produce short circuit currents high enough to weld a ring or the like to metal, causing a severe burn.

Preparing to Charge Precautions

Before charging a battery with the charger, read the following precautions:

1. Do **NOT** operate the charger if the cables or an LED is damaged.
2. Make sure all accessories on the product you are charging are **OFF**.
3. If the battery or batteries must be removed from the product, always remove the grounded terminal from the battery first.
4. Be sure the area around the battery is well ventilated while the battery is being charged. Gas can be forcefully blown away using a piece of cardboard or other non-metallic material as a "hand fan".
5. Clean battery terminals. Be careful to keep corrosion from coming in contact with eyes.
6. Add distilled water in each cell until battery acid reaches levels specified by the battery manufacturer, if applicable. Do not overfill. For all batteries, carefully follow the manufacturer's recharging instructions.
7. Never allow the ring terminals to touch each other.
8. **NEVER** charge a frozen battery.
9. Please be sure the DC system to which the charger is connected is not drawing excessive current from the battery for extended periods of time while the charger is operating. This is important to ensure the charger correctly transitions through each charging stage to finish with the float voltage level. If the DC system is drawing continuous current while charging, reduced life or damage to the battery may occur.

2. INSTALLING THE CHARGER

AC Connection and Grounding Precautions:

DANGER

DO NOT OPERATE THIS CHARGER WITH A TWO BLADED ADAPTER PLUG OR EXTENSION CORD. DOING SO CAN RESULT IN SERIOUS PERSONAL INJURY. DO NOT ATTEMPT TO WIRE THE BATTERY CHARGER USING AN ELECTRICALLY ENERGIZED LINE CORD. WIRE THE CHARGER ONLY WHILE THE WIRING OR AC SOURCE IS DE-ENERGIZED. AFTER SECURING THE BATTERY CONNECTIONS, PLUG THE AC LINE CORD INTO AN AVAILABLE AC OUTLET THAT IS PROTECTED BY A GROUND FAULT CIRCUIT INTERRUPTER (GFCI) BREAKER. DO NOT PLUG INTO AC UNTIL ALL CHARGER CONNECTIONS ARE MADE.

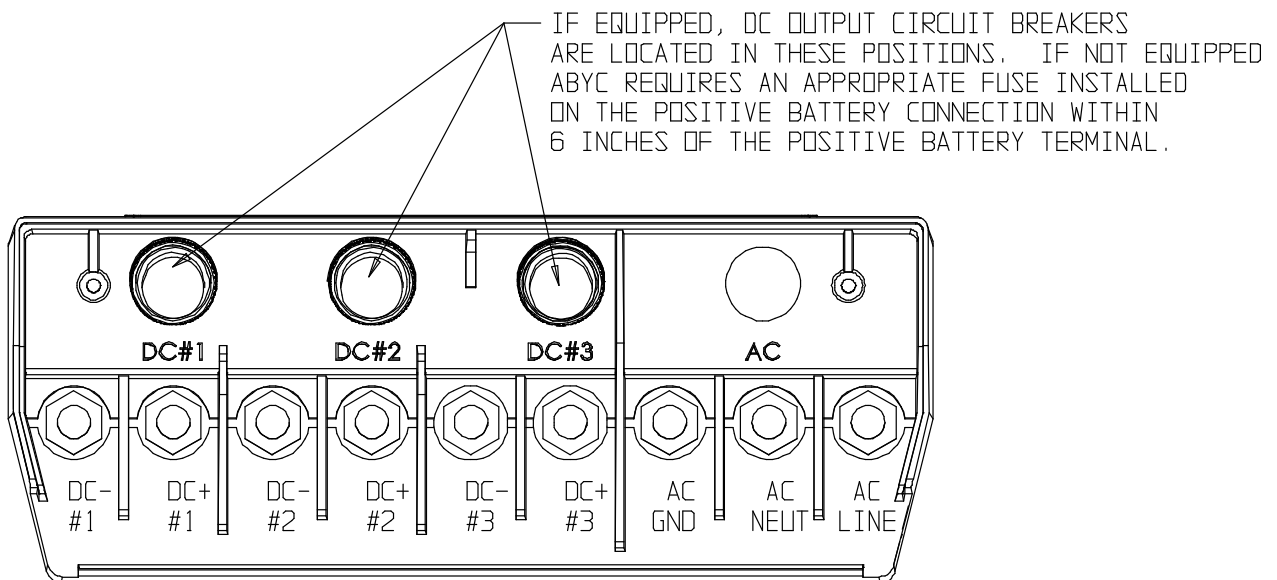

Making AC Connections:

Reference the above drawing:

1. Make AC connections to the charger by wiring AC Hot or Line to the AC LINE terminal, wire AC Neutral to the AC NEUT terminal, wire Earth Ground to the AC GND terminal.
2. To interface between the conductor and the stud terminal, use either a fork or ring terminal appropriately sized for a 1/4" stud.

- For 230 Vac chargers, the AC and DC wiring method is identical to 115 Vac chargers.

Note: US Color Code is Black = Line, White = Neutral, Green or Non Insulated = Earth Ground.

Euro color coding is Brown = Line; Blue = Neutral; Green, Green/Yellow or Non Insulated = Earth Ground.

CAUTION: To reduce the risk of shock, connect only to a properly grounded outlet.

AC Cable size Guidelines:

For AC Cable lengths 6 feet and under use 3 conductor 18 AWG cable.

For AC Cable lengths 6 feet to 12 feet use 3 conductor 16 AWG cable

For AC Cable lengths 12 feet to 18 feet use 3 conductor 14 AWG cable

Making DC Connections:

Notes:

- Check polarity of the battery posts. The POSITIVE (POS., P, +) battery post usually has a larger diameter than the NEGATIVE (NEG., N, -) post.

- Connections to the battery should be made with industry standard color coding. Connections to the positive terminal should be made with RED wire, connections to the negative terminal should be made with BLACK or YELLOW wire.

DC Cable size Guidelines:

Charger Output Size	Up to 6 feet	6 – 10 feet	10 – 15 feet
20 Amp Output	2 conductor 12 AWG	2 conductor 10 AWG	2 conductor 8 AWG
10 Amp Output	2 conductor 14 AWG	2 conductor 12 AWG	2 conductor 10 AWG
5 Amp Output	2 conductor 14 AWG	2 conductor 14 AWG	2 conductor 12 AWG

FOR FURTHER INFORMATION REGARDING AC AND DC WIRING STANDARDS PLEASE SEE ABYC (AMERICAN BOAT AND YACHT COUNCIL) STANDARDS AND TECHNICAL INFORMATION REPORTS FOR SMALL CRAFT, SECTION E-11.

SEE DIAGRAMS IN SECTION 3 FOR SPECIFIC DETAILS ON DC CONNECTIONS.

Circuit Breaker Operation for chargers equipped with circuit breakers:

For chargers equipped with circuit breakers, the circuit breaker will trip, or open, during an over current situation. This can be caused by connecting the charger in reverse polarity across the battery. To reset the breaker, first disconnect the charger from the battery, then push the circuit breaker button. Then reconnect the charger to the battery using correct polarity.

Output Cable Fusing: Guest recommends that all chargers be installed with an in-line fuse on each DC positive output per ABYC standards.

If the Guest Cruising Series charger does not come equipped with circuit breakers, an inline fuse ***must*** be installed in series with each DC positive output cable to the battery. This is to prevent catastrophic destruction of the charger in the event of reverse polarity connection.

CHARGER	OUTPUT 1	OUTPUT 2	OUTPUT 3
2632A	15 AMP FUSE	15 AMP FUSE	25 AMP FUSE
2633A	15 AMP FUSE	25 AMP FUSE	NOT APPLICABLE

Choosing Charging Location:

The charger should have at least eight inches of unobstructed area on all sides of the unit for effective cooling. The case of this charger will become warm during operation. Because the charger is convection cooled (airflow over the back of the charger), the optimum mounting position for the charger is vertical. Mounting on its back on a horizontal surface may cause the charger to slightly reduce amperage output due to the thermal protection built in. Do not install the charger on carpeted, upholstered, or varnished surfaces.

Mounting the Charger:

1. Use corrosion resistant 1/4" dia. bolts, backed by a flat washer, and secured to the mounting surface with a split-ring lock washer.
2. Hold the charger to the mounting surface and mark the holes.
3. Remove the charger and drill the mounting holes.
4. Align the charger and assemble the mounting hardware. Secure.

Battery Size Recommendations

The recommended maximum battery size per 5 amp bank is 60AH.

The recommended maximum battery size per 10 amp bank is 120AH.

The recommended maximum battery size per 20 amp bank is 240AH.

3. CHARGER SPECIFIC WIRING DRAWINGS

2632A Connections

Model	Output Volts	Output Amps	Banks	Output Circuit Breakers	Input Volts	Input Amps Max
2632A	12/12/12	5/5/20	3	YES	115VAC 50/60Hz	7.5 Amp
2632A-230	12/12/12	5/5/20	3	YES	230VAC 50/60Hz	3.75 Amp

Diagram 1. Standard Connections for a 2632A (5/5/20 Amps) used with 3 independent 12V Batteries

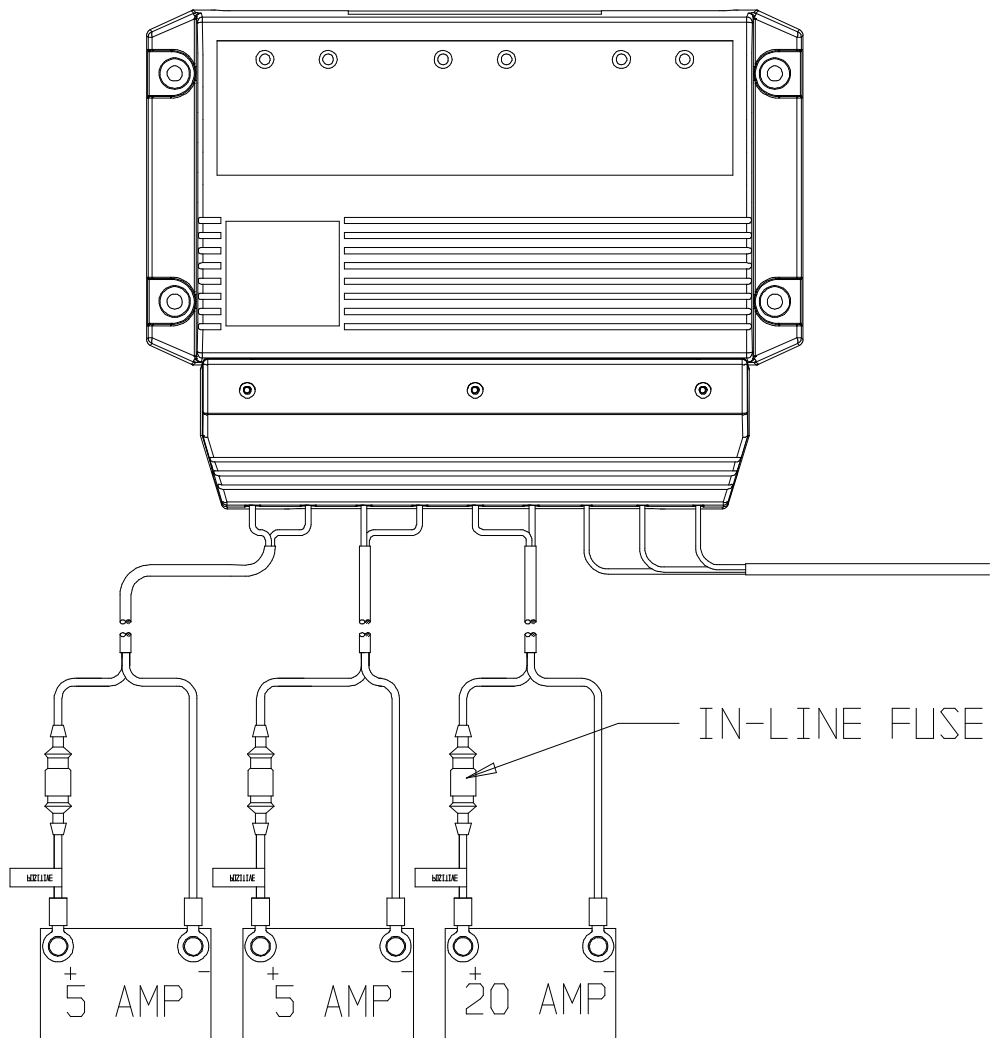
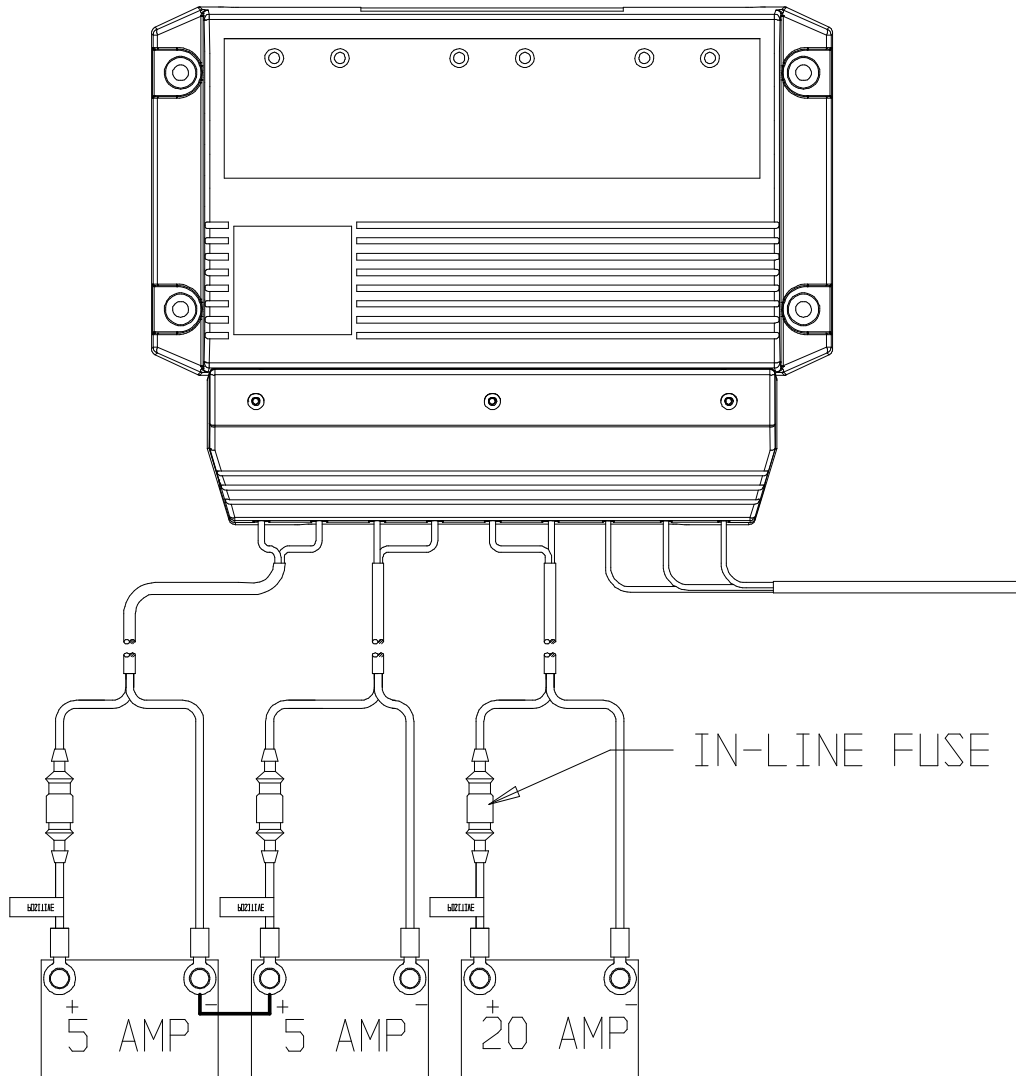

Diagram 2. Standard Connections for a 2632A (5/5/20 Amps) used with 2 12V batteries wired in series for a 24 V system, and one other 12 V battery



2632A Connection Warnings: Do NOT connect the outputs of the 2632A in series or in parallel while charger is AC powered ON. Charge separate batteries only while charger is AC powered on, battery switch must be set to “OFF”, “1”, or “2”, not “both”.

2633A Connections

Model	Output Volts	Output Amps	Banks	Output Circuit Breakers	Input Volts	Input Amps Max
2633A	12/12	10/20	2	YES	115VAC 50/60Hz	7.5 Amp
2633A-230	12/12	10/20	2	YES	230VAC 50/60Hz	3.75 Amp



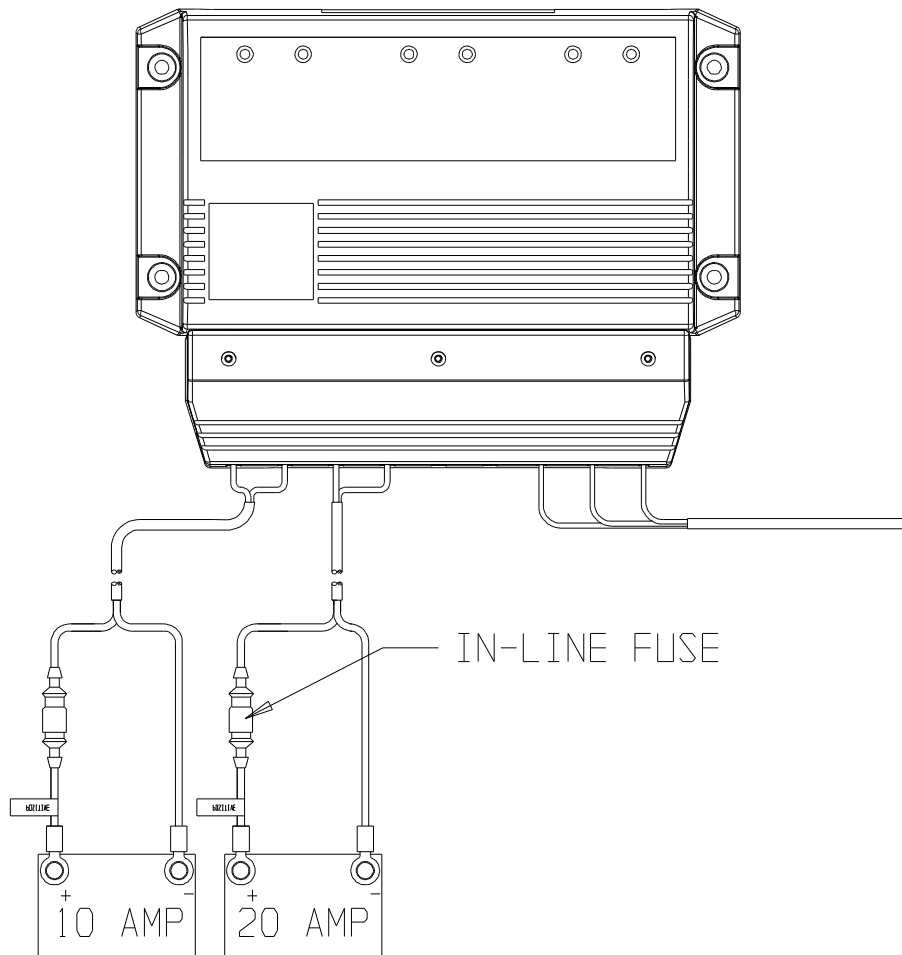



Diagram 3. Standard Connections for a 2633A (10/20 Amps) used with 2 independent 12V Batteries



2633A Connection Warnings: Do NOT connect the outputs of the 2633A in series or in parallel while charger is AC powered ON. Charge separate battery systems only. While charger is AC powered on, battery switch must be set to “OFF”, “1”, or “2”, not “both”.







4. OPERATING THE CHARGER – 10 (or 5/5) amp output

The LED Function Chart describes the charging process for any 10 (or 5/5) Amp output.

Display	Operating condition
Red  Green 	<p>When the red LED is on, it indicates that your batteries are discharged and is recharging them at the "Charging" rate (stage 1). This charging rate is 10 Amps.</p> <p>While the red LED is on, the voltage measured (with the charger on) will be approximately 11.5 to 13 Volts.</p> <p>If the red LED stays on for more than 24 hours, refer to Problem 1 in the troubleshooting section in this manual.</p>
Red  Green 	<p>When both the green and the red LED's are on, it is charging at the "Finishing" rate. (stage 2). During this second charging stage, the charger holds the battery voltage at approximately 14.3 VDC, and then gradually reduces the amount of current (Amps) it delivers to the battery. By doing this, the battery is able to "absorb" the last 10% of charge as quickly as possible without becoming overheated.</p> <p>If both lights stay on longer than 24 hours, refer to Problem 2 in the troubleshooting section in this manual.</p>
Red  Green 	<p>When the battery approaches full charge, the charger switches into its third charging stage, gradually reducing the current fed to the batteries to as low as 0.1 Amps. At the same time, it reduces its output voltage to a "Float" or "Ready" charging rate of approximately 13.3 VDC, indicated by the green LED light. This low "Float" or "Maintenance" voltage gently "tops off" your batteries, keeping them fully charged and ready until needed. The green LED indicates that your batteries are now fully charged and ready for use.</p> <p>If the green LED stays on when your battery is known to be low, refer to Problem 3 in the troubleshooting section in this manual.</p>

OPERATING THE CHARGER – 20 amp output

The LED Function Chart describes the charging process for any individual 20 Amp output.

Display	Operating condition
Red  Green 	<p>When the red LED is on, it indicates that your batteries are discharged and is recharging them at the "Charging" rate (stage 1). This charging rate is 20 Amps.</p> <p>While the red LED is on, the voltage measured (with the charger on) will be approximately 11.5 to 13 Volts.</p> <p>If the red LED stays on for more than 24 hours, refer to Problem 1 in the troubleshooting section in this manual.</p>
Red  Green 	<p>When both the green and the red LED's are on, it is charging at the "Finishing" rate. (stage 2). During this second charging stage, the charger holds the battery voltage at approximately 14.3 VDC, and then gradually reduces the amount of current (Amps) it delivers to the battery. By doing this, the battery is able to "absorb" the last 10% of charge as quickly as possible without becoming overheated.</p> <p>If both lights stay on longer than 24 hours, refer to Problem 2 in the troubleshooting section in this manual.</p>
Red  Green 	<p>When the battery approaches full charge, the charger switches into its third charging stage, gradually reducing the current fed to the batteries to as low as 0.1 Amps. At the same time, it reduces its output voltage to a "Float" or "Ready" charging rate of approximately 13.3 VDC, indicated by the green LED light. This low "Float" or "Maintenance" voltage gently "tops off" your batteries, keeping them fully charged and ready until needed. The green LED indicates that your batteries are now fully charged and ready for use.</p> <p>If the green LED stays on when your battery is known to be low, refer to Problem 3 in the troubleshooting section in this manual.</p>

5. TROUBLESHOOTING

Problem	Cause	Solution
1. Red LED stays on for more than 24 Hrs.	<ol style="list-style-type: none"> 1. One or more defective or damaged cells. 2. Charger has reduced its output voltage below the normal level due to a DC overload or a DC short. 3. On-board DC systems are drawing more current than the charger can replace. 	<ol style="list-style-type: none"> 1. Load test the batteries and replace if necessary. 2. Remove the source of the overload or short. Disconnect the charger's black (NEGATIVE) ring terminal from the battery. Reapply AC power and the green LED only should now light. 3. Turn off all DC equipment while charging.
2. The red and green LED's stay on for more than 24 Hrs.	<ol style="list-style-type: none"> 1. On-board DC systems are drawing enough current to prevent the charger from switching into the Float or Ready State. 2. One or more defective or damaged cells. 3. Extremely low AC voltage at the battery charger. 	<ol style="list-style-type: none"> 1. Turn off all DC equipment while charging. 2. Load test the batteries and replace if necessary. 3. Apply a higher AC voltage source or reduce the length of the extension cord. 4. Check battery manufacturer's specs on battery charging.
3. Green LED stays on when the battery is known to be low.	<ol style="list-style-type: none"> 1. Open circuit breaker or DC output fuse. 2. Faulty or contaminated terminal connections. 3. One or more defective or damaged cells. 	<ol style="list-style-type: none"> 1. Check connections to the battery, reset circuit breaker if equipped/replace fuse. 2. Clean and tighten or repair all terminal connections. 3. Load test the batteries and replace if necessary.
3. Neither of the LED's turn on when the AC power is applied.	<ol style="list-style-type: none"> 1. No AC power available at the charger 2. Charger failure 	<ol style="list-style-type: none"> 1. Connect AC power or reset the AC breaker on the main panel 2. Return charger to the Guest Service Dept.

6. MAINTAINING THE CHARGER

Periodically clean both battery terminals with baking soda and tighten all connections. No other maintenance on the charger is required.

7. SPECIFICATIONS

Model	Output Volts	Output Amps	Banks	Output Circuit Breakers	Input Volts	Input Amps Max
2632A	12/12/12	5/5/20	3	YES	115VAC 50/60Hz	7.5 Amp
2632A-230	12/12/12	5/5/20	3	YES	230VAC 50/60Hz	3.75 Amp
2633A	12/12	10/20	2	YES	115VAC 50/60Hz	7.5 Amp
2633A-230	12/12	10/20	2	YES	230VAC 50/60Hz	3.75 Amp

FCC Class A EMC Notice

This equipment has been tested and found to comply with the limits for a Class A digital device, pursuant to part 15 of the FCC Rules. These limits are designed to provide reasonable protection against harmful interference when the equipment is operated in a commercial environment. This equipment generates, uses and can radiate radio frequency energy and, if not installed and used in accordance with the instructions, may cause harmful interference to radio communications. Operation of this equipment in a residential area is likely to cause harmful interference in which case the user will be required to correct the interference at his own expense.

If this equipment does cause harmful interference to radio or television reception, which can be determined by turning this equipment off and on, the user is encouraged to try to correct the interference by one or more of the following measures:

- Reorient or relocate the receiving antenna.
- Increase the separation between the equipment and receiver.
- Connect the equipment into an outlet on a circuit different from that to which the receiver is connected.

LIMITED WARRANTY

For two (2) years from the date of purchase, The Guest Co. will, at its discretion, repair or replace for the original consumer, free of charge, any parts found defective in material or workmanship.

This product is guaranteed for life against water damage.

Proof of purchase is required: A computerized register receipt is required. Hand-written receipts are not accepted for warranty proof of purchase.

There is no other expressed warranty. Implied warranties, including those of merchantability and fitness for a particular purpose, are limited to two years from the date of purchase. This is the exclusive remedy and consequential damages are excluded where permitted by law.

Tel: (707) 226-9600

Fax: (707) 226-9670

Email: info@marinco.com

Website: www.marinco.com

728956 Rev G 3429